

BOLTLINE Hollow Block

KOBRA BOLTLINE: Hollow Block

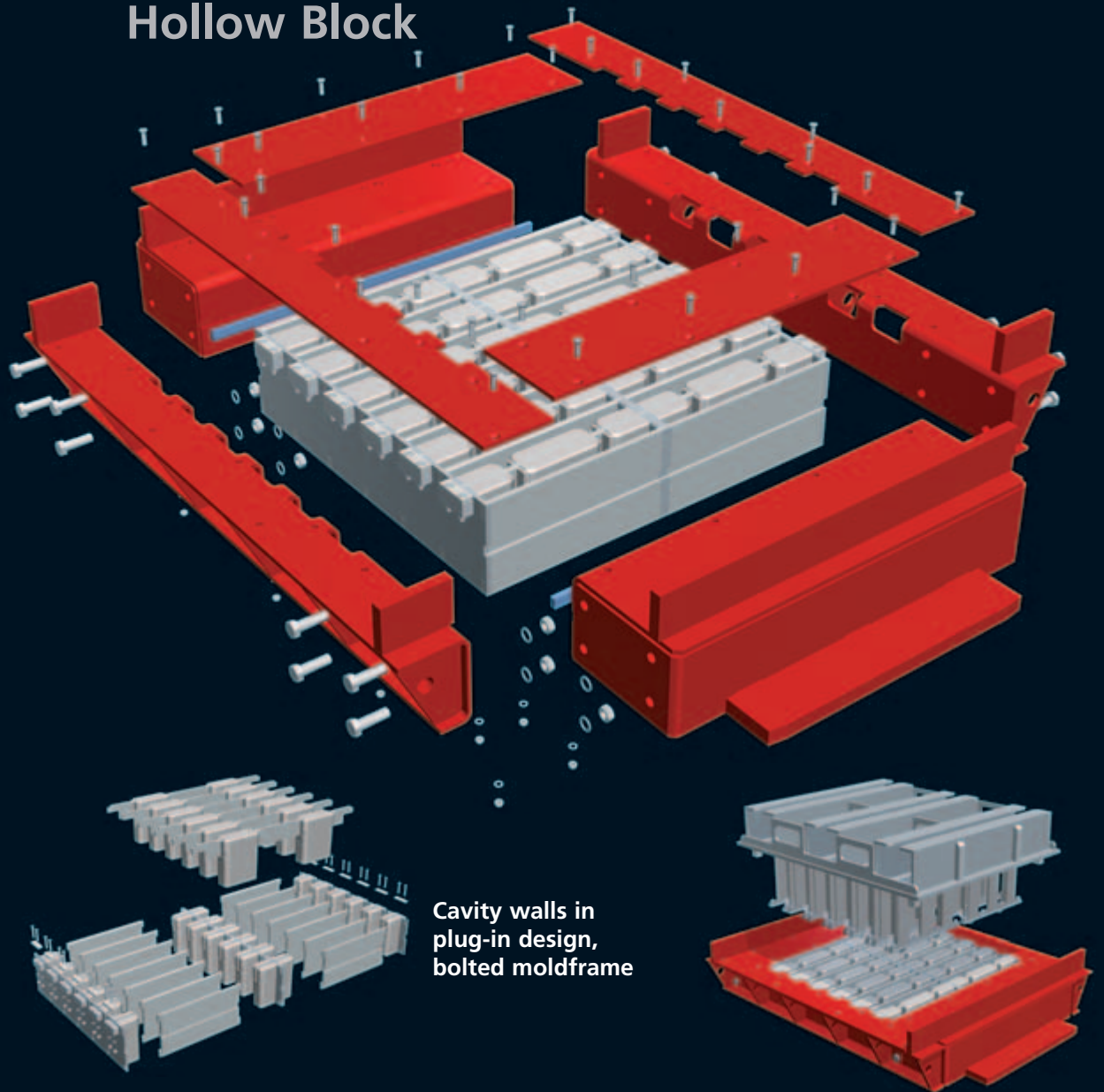

Cavity walls in
plug-in design,
bolted moldframe



Oscillating mold walls

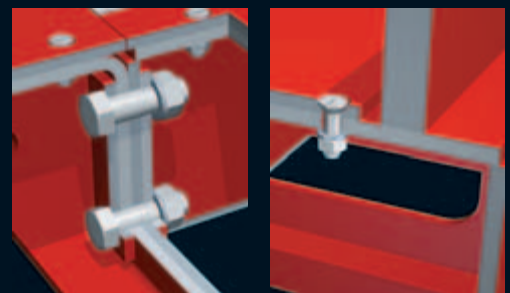

All parts with a solid bolt connection,
frame corners with special fitting bolt



KOBRA Molds, L.L.C.
6555 Garden Road,
Suite 17
Riviera Beach, FL 33404
USA
Phone 001-561-842-6522
Fax 001-561-842-9777
kobrana@bellsouth.net



KOBRA Formen GmbH
Plohnbachstraße 1
08485 Lengenfeld
Deutschland
Telefon +49 37606 302-0
Fax +49 37606 302-22
www.kobra-formen.de
post@kobra-formen.de

BOLTLINE

BOLTLINE[®]

KOBRA
F O R M E N

BOLTLINE®

KOBRA BOLTLINE molds have individually plugged-in cavity walls which are easy to replace. We get an oscillation effect similar to our DYNAMIC system.

Advantages:

- better consistency (smoother stone sides)
- higher strength/density
- better finish
- easier filling
- cost effective repairs utilizing exchangeable wear parts
- available for curbstone and hollow block molds

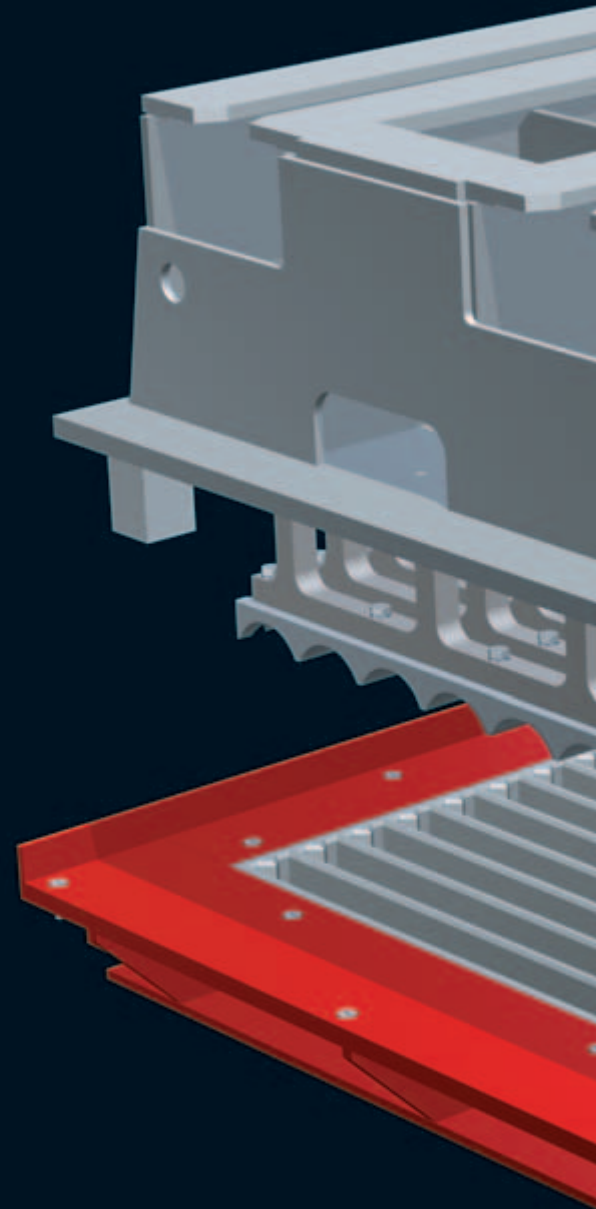

The KOBRA BOLTLINE mold is a technical masterpiece

KOBRA BOLTLINE:
Curbstone

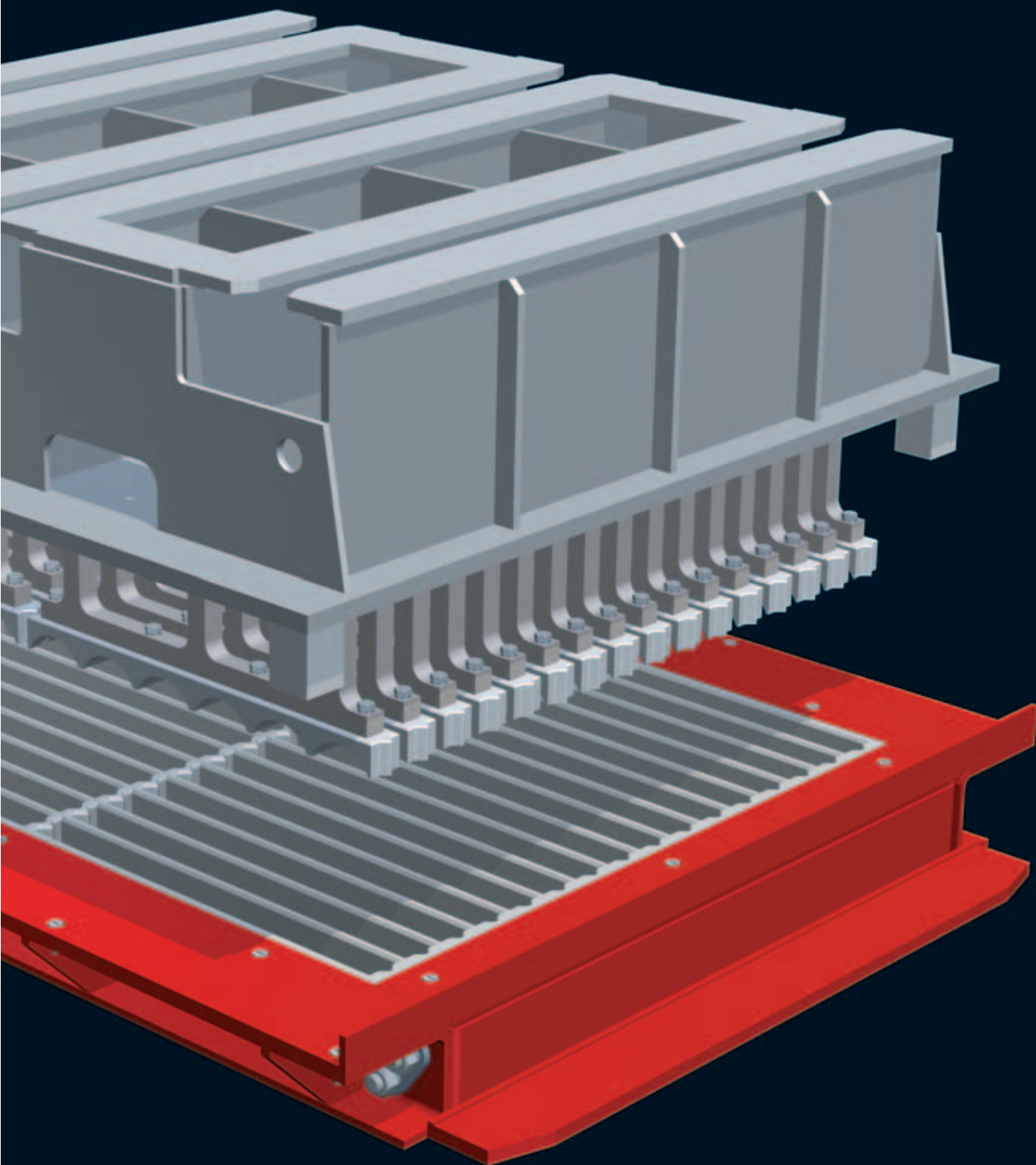

KOBRA BOLTLINE: Curbstone

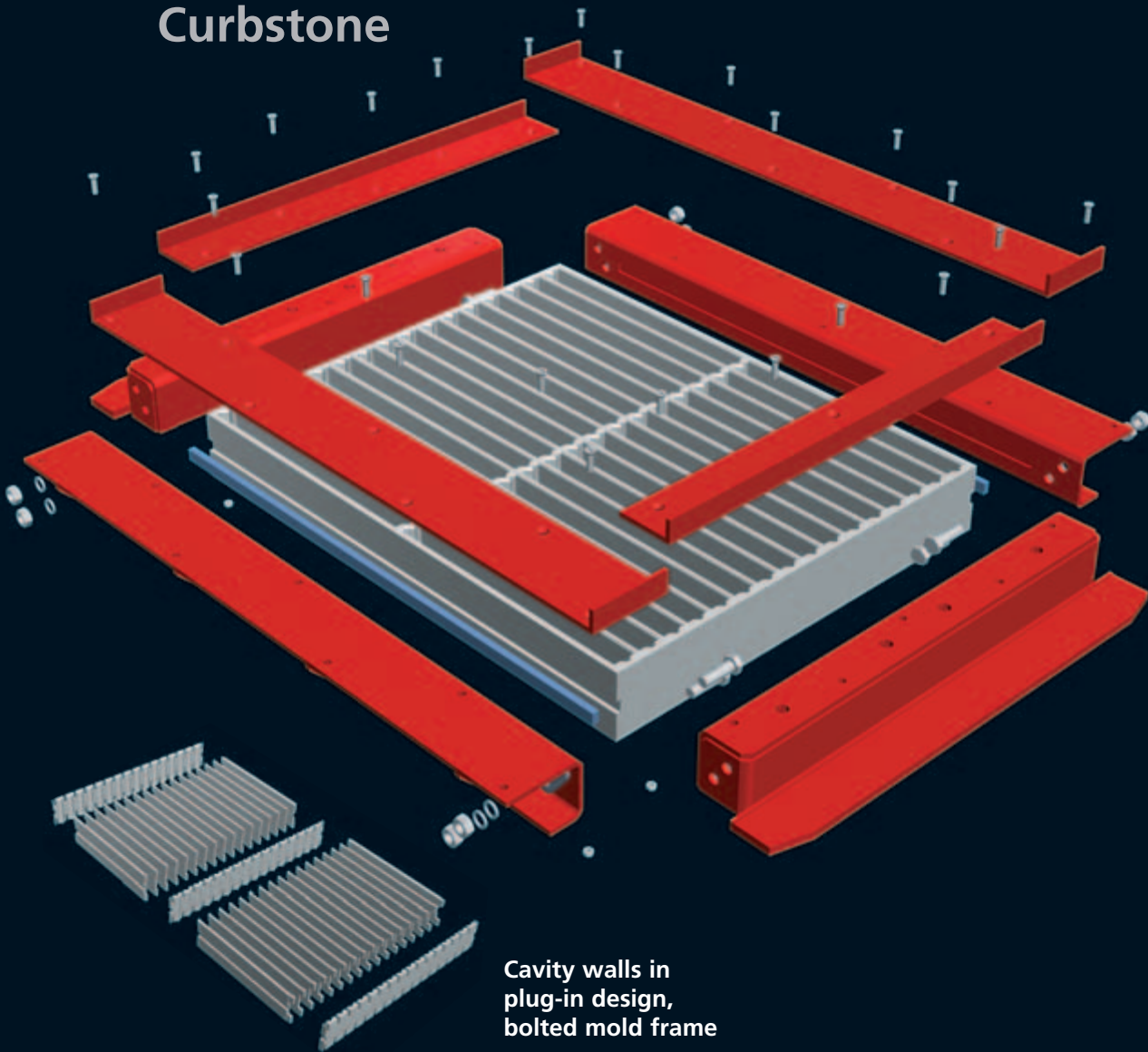

Cavity walls in
plug-in design,
bolted mold frame

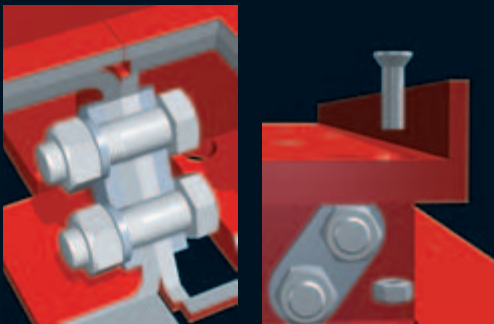

All parts with a solid bolt connection,
frame corners with special fitting bolt

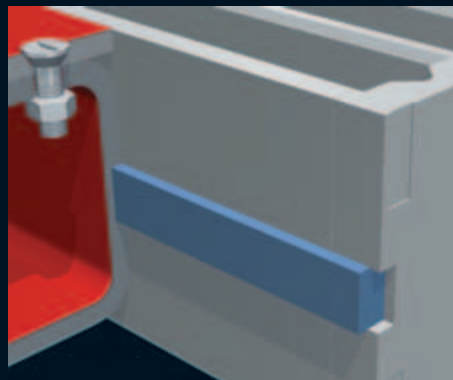

Oscillating mold walls